

# Gassero

technology for your comfort



ECO-FRIENDLY

## WALL MOUNT CONDENSING BOILERS

[www.gassero.com](http://www.gassero.com)

# Wall Mount Boilers

## Wallcon



Capacity (kW)				
42	50	67	70	80
●	●	●	●	●

## Wallcon X-treme



Capacity (kW)				
115	125	150	180	200
●	●	●	●	●

## Alucon



Capacity (kW)								
42	50	67	70	80	90	115	125	150
	●		●		●	●	●	●

# Wall Mount Boilers

## Wallcon

- › 42-80 kW capacity range,
- › Stainless Steel Heat Exchanger
- › Low NOx values
- › Low flue gas temperatures
- › Turndown ratio up to 15:100
- › Efficiency up to %107,2 according to EN 15502-1+A1
- › Suitable with B23, C13, C33, C43, C53, C63, C83 flue types

## Wallcon X-treme

- › 115-150- 200 kW capacity range,
- › Stainless Steel Heat Exchanger
- › Low NOx values
- › Low flue gas temperatures
- › Turndownratio up to 15:100
- › Efficiency up to %107,2 according to EN 15502-1+A1
- › Suitable with B23, C13, C33, C43, C53, C63, C83 flue types

## Alucon

- › 50-150 kW capacity range,
- › Aluminum heat exchanger
- › Low NOx values
- › Low flue gas temperatures
- › Turndown ratio up to 14:100
- › Efficiency up to %108,2 according to EN 15502-1+A1
- › Suitable with B23, C13, C33, C43, C53, C63, C83 flue types

## Premix and Condensation Technology Explained

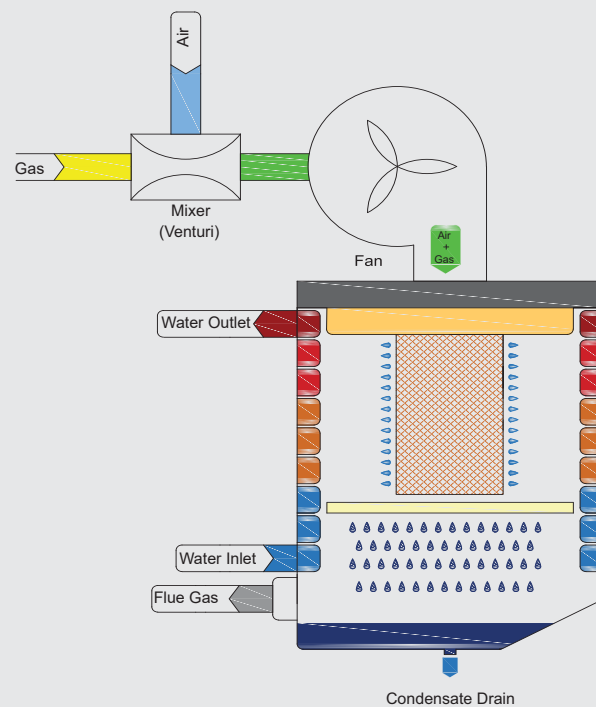

Condensation technology is an effective method for converting natural gas into beneficial energy by combustion. Hidden energy of hot flue gas in water vapor gain into the system and provides energy efficiency.

Condensing boilers are operate with low flue gas temperatures. Miixing of the air and gas used in the energy production to obtain an efficient combustion before get inside the combustion chamber is named as premix.

Premix systems provide lower emissions values (NOx-CO) after combustion.

# Wallcon & Wallcon X-treme

Wall Mount Condensing Boiler



- › 42-150 kW capacity range
- › Stainless steel heat exchanger
- › Low NOx values
- › Low flue gas temperatures
- › Turndown ratio up to 15:100
- › Integrated cascade management up to 16 boilers
- › Low noise level
- › Efficiency up to %107,2 according to EN 15502-1+A1
- › Integrated circulating pump
- › Energy class A
- › 6 Bar operation pressure

## Product Specifications



- › Efficient and durable heat exchanger
- › ErP circulating pump
- › Latest technology, low emission premix burner
- › High modulating and energy-efficient fan

### Safety Features:

- Frost protection
- Overheat protection
- Low and high water pressure safety
- Flue gas temperature and pressure safety
- Pump/valve protection
- Legionella protection for DHW tank
- Condensate blockage safety with siphon sensor
- Fan speed safety

# Wallcon & Wallcon X-treme

## Technical Specifications

	WALLCON					WALLCON X-treme					
	42	50	67	70	80	115	125	150	180	200	
<b>Thermal Specifications</b>											
Nominal heat input Qn	kW	7,2/39,4	8,4/48,0	11,2/63,0	11,2/66,0	11,2/76,0	17,0/108,5	17,0/121,0	21,9/143,0	29,0/171,0	32,0/190,0
Nominal heat output Pn (80/60°C)	kW	7,0/38,3	8,1/46,3	11,0/61,0	10,9/64,5	10,9/74,1	16,6/105,4	16,6/117,5	21,2/139,6	28,3/166,4	31,2/184,5
Nominal heat output Pnc (50/30°C)	kW	7,6/41,3	8,9/50,1	12,0/67,0	12,0/67,0	12,1/80,9	18,4/115,5	18,4/127,6	23,7/150,7	31,2/180,5	34,3/200,4
Heating efficiency pu,n (80/60°C)	%	96,30/97,37	95,62/97,40	98,02/97,62	97,31/97,72	97,31/97,61	97,34/97,26	97,34/97,15	97,07/97,68	97,87/97,32	97,60/97,13
Heating efficiency pu,n (50/30°C)	%	106,42/105,21	106,96/105,14	107,42/106,58	107,98/106,57	107,98/106,55	108,23/106,53	108,23/105,46	107,70/105,40	107,89/105,57	107,38/105,51
Partial load efficiency pu (36/30°C)	%	108,20	108,08	108,16	108,39	108,34	108,12	108,04	108,34	108,48	108,42
Turndown ratio		18-100	18-100	18-100	17-100	15-100	16-100	14-100	15-100	17-100	17-100
<b>Hydraulic Specifications</b>											
Working water pressure	bar	0,8/3,0	0,0/0,0	0,8/3,0	0,8/4,0	0,8/4,0	0,8/4,0	0,8/4,0	0,8/6,0	0,8/6,0	0,8/6,0
Water flow rate	m³/h	0,26/1,62	0,34/1,98	0,49/2,73	0,49/2,86	0,49/3,30	0,65/5,12	0,65/5,26	0,86/6,31	1,35/7,83	1,49/8,45
Pump delivery head	mWC	6,0	5,9	4,2	4,0	3,4	7,70	7,20	10,60	7,60	6,00
Max. operating temp.	°C	80	80	80	80	80	80	80	80	80	80
Limit thermostat shut off temp.	°C	100	100	100	100	100	105	105	105	105	105
Heat exchanger water volume	lt	2,74	2,74	2,74	3,52	3,52	8,20	8,20	9,70	13,10	13,10
Hydraulic loss	kPa	30	40	44	40	55	40	41	39	40	46
<b>Gas Specifications</b>											
Gas type	-	G20/G25/G30/G31								G20	
Gas category	-	I2E, I2H, I2ELL, I3B/P, I3P, I3+, II2H3BP, II2H3P, II2H3+, II2E3B/P, II2ELL3B/P, II2E3P, II2ELL3P								I2E, I2H	
<b>Gas and combustion Specifications, G20</b>											
Gas supply pressure	mbar	20	20	20	20	20	20	20	20	20	20
Flue Type	-	B23/C13/C33/C43/C53/C63/C83				B23	B23/C13/C33/C43/C53/C63/C83				B23
Flue gas pressure	Pa	100	140	170	190	210	200	190	310	550	500
Combustion products mass flow rate	g/sn	3/17	4/21	5/28	5/28	5/30	12/47	8/49	9/60	13/74	14/81
Max flue length (B23)	m	25	25	25	25	25	-	-	-	-	-
Max flue length (C13/C33/C43/C53/C63/C83)	m	15	15	15	14	-	17	17	17	-	-
CO <sub>2</sub> emission	%	9,20/9,60	9,20/9,60	9,03/9,25	9,20/9,10	9,20/9,40	9,10/9,10	9,10/9,10	9,35/9,78	9,05/9,30	8,91/9,47
CO emission	ppm	1/121	1/121	12/81	1/82	12/115	2/56	2/98	0/208	6/142	6/190
O <sub>2</sub>	%	4,60/3,90	4,60/3,90	4,97/4,37	4,90/5,00	4,90/4,50	4,70/4,70	4,70/4,70	4,33/3,45	5,20/4,64	5,36/4,42
Flue gas temp. (80/60°C) (min/max)	°C	63,5/65,3	65,1/78,0	56,9/69,9	62,7/72,8	62,70/75,40	58,9/78,3	56,9/73,9	57,10/72,90	58,30/74,30	61,7/78,6
Flue gas temp. (50/30°C) (min/max)	°C	40,4/42,1	43,5/55,7	35,1/47,7	39,6/51,8	39,60/54,30	33,6/40,6	31,9/56,4	31,80/54,90	32,00/55,70	36,9/61,4
Flue gas overheat temperature	°C	85	85	85	85	85	85	85	85	85	85
NO <sub>x</sub> class	-	6	6	-	-	-	-	-	-	-	-
NO <sub>x</sub> value	mg/kWh	44	52	52	21	23	24	34	27	28	30
Gas consumption	m³/h	0,70/3,86	0,81/4,85	1,09/6,43	1,11/6,85	1,11/7,48	2,65/10,70	1,56/11,27	2,07/13,28	3,18/17,88	3,39/20,49
Integrated backdraught shutter	-	VAR	VAR	VAR	VAR	VAR	VAR	VAR	VAR	VAR	YOK
<b>Connection Specifications</b>											
Boiler water inlet/outlet diameter	DN	25/25	25/25	25/25	25/25	25/25	32/32	32/32	32/32	40/40	40/40
Air inlet/outlet diameter (B23)	mm	80/80	80/80	80/80	80/80	80/80	110/100	110/100	110/100	110/150	110/150
Air inlet/outlet diameter (C13/C33/C43/C53/C63/C83)	mm	125/80	125/80	125/80	125/80	-	150/100	150/100	150/100	-	-
Gas supply diameter	DN	20	20	20	20,0	20,0	25	25	25	25	25
<b>Electrical Specifications</b>											
Power supply	V/Hz	230/50	230/50	230/50	230/50	230/50	230/50	230/50	230/50	230/50	230/50
Electrical consumption	W	120	130	190	180	204	350	360	461	261	295
<b>General Specifications</b>											
Exchanger type	-	PASLANMAZ ÇELİK									
Energy efficiency class	-	A	A	-	-	-	-	-	-	-	-
Sound power level (Lwa)	dB(A)	53,5	55,5	63,0	70,0	71,1	58,5	60,4	61,7	-	-
Sound pressure level (from 1m distance)	dB(A)	45,4	47,5	52,0	65,1	66,1	50,5	52,4	53,7	-	-
Boiler dimensions (Width/Length/Height)	mm	485/490/612	485/490/612	485/490/612	485/540/612	485/540/612	557/580/865	557/580/865	557/580/865	557/725/910	557/815/910
Boiler weight (Net)	kg	46	46	46	50	50	86	86	95	125	130
<b>Packaging Specifications</b>											
Packing dimensions (Width/Length/Height)	mm	540/1010/570	540/1010/570	540/1010/570	640/1020/550	640/1020/550	650/1190/690	650/1190/670	650/1190/690	630/780/1200	930/870/1200
Boiler weight (Gross)	kg	53	53	53	57	57	93	93	102	140	150

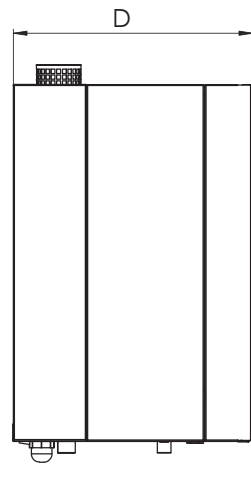
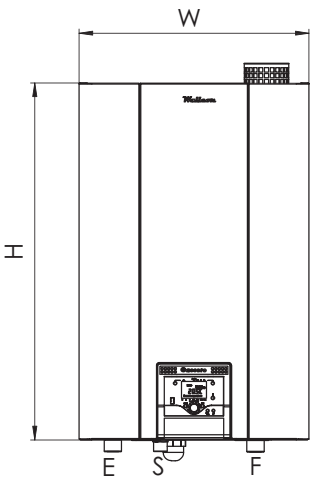

Wallcon 42 - 50 - 67 - 70 - 80

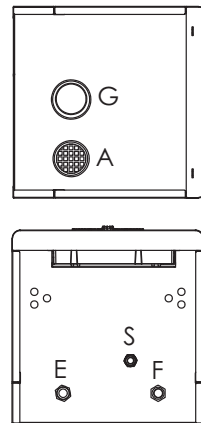

Wallcon X-treme 115 - 125 - 150

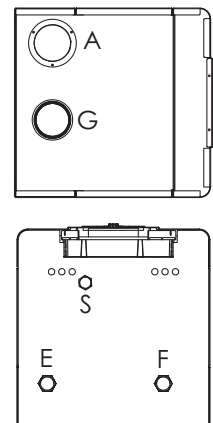



# Alucon

Wall Mount Condensing Boiler



- 50-150 kW capacity range
- Aluminum heat exchanger
- Low NOx values
- Low flue gas temperature
- Turndown ratio up to 14:100
- Cascade operation option up to 16 boilers
- Low noise level
- Efficiency up to %108,2 according to EN 15502-1+A1
- With external circulation pump
- Energy class A
- 6 Bar operation pressure



## Product Specifications



- High corrosion and lime resistance
- Circulation pump suitable with ErP regulation
- Low emission premix burner
- High modulating and energy-efficient fan

### Safety Features:

- Frost protection
- Overheat protection
- Low and high water pressure safety
- Flue gas temperature and pressure safety
- Pump/valve protection
- Legionella protection for DHW tank
- Condensate blockage safety with siphon sensor
- Fan speed safety

ALUCON							
		50	70	90	115	125	150
<b>Thermal Specifications</b>							
Nominal heat input Qn	kW	7,6/49,2	10,2/65,6	14,9/88,3	14,9/112,3	19,9/123,5	19,9/143,1
Nominal heat output Pn (80/60°C)	kW	7,3/47,8	9,9/63,4	14,3/86,3	14,3/109,5	19,2/120,8	19,2/139,8
Nominal heat output Pnc (50/30°C)	kW	8,4/51,4	11,6/68,5	15,1/91,0	15,1/118,1	22,3/128,0	22,3/149,1
Heating efficiency $\eta_{u,n}$ (80/60°C)	%	96,9/97,7	96,7/97,2	96,8/98,4	96,8/98,2	97,0/98,3	97,0/98,2
Heating efficiency $\eta_{u,n}$ (50/30°C)	%	108,1/105,9	108,0/103,9	108,2/105,0	108,2/104,8	108,1/104,4	108,1/103,2
Partial load efficiency $\eta_p$ (36/30°C)	%	108,6	108,4	108,5	108,7	108,5	108,4
Turndown ratio		16:100	16:100	17:100	14:100	17:100	14:100
<b>Hydraulic Specifications</b>							
Working water pressure	bar	0,8/6,0	0,8/6,0	0,8/6,0	0,8/6,0	0,8/6,0	0,8/6,0
Heat exchanger water volume	lt	3,2	3,2	4,6	4,6	6	6
Water flow rate	m <sup>3</sup> /h	0,3/2,2	0,4/3,0	0,6/3,8	0,6/5,0	0,8/5,4	0,8/6,2
Pump delivery head	mSS	3	3			5,5	5,5
Limit thermostat shut off temp.	°C	85	85	85	85	85	85
<b>Gas and combustion Specifications, G20</b>							
Gas type		G20	G20	G20	G20	G20	G20
Gas supply pressure	mbar	20/25	20/25	20/25	20/25	20/25	20/25
Flue Type		B23/C13/C33/C43/C53/C63/C83					
Flue gas pressure	Pa	100	130	170	200	220	330
Combustion products mass flow rate	gr/sn	3,0/22,0	5,0/28,0	6,0/39,0	6,0/49,0	9,0/54,0	9,0/63,0
CO <sub>2</sub> emission	%	9,3/9,40	9,1/9,6	9,4/9,3	9,4/9,4	9,5/9,5	9,5/9,6
CO emission	ppm	44/89	29/152	27/120	27/156	24/141	24/169
Flue gas temp. (80/60°C) (min/max)	°C	54,7/65,6	55,4/72,1	56,8/61,4	56,8/64,9	56,9/61,8	56,9/70,3
Flue gas temp. (50/30°C) (min/max)	°C	29,5/45,1	30,1/52,3	30,2/44,8	30,2/53,5	30,5/44,9	30,5/47,1
NO <sub>x</sub> class		6	6				
NO <sub>x</sub> value	mg/kWh	37	28	39	43	46	44
Gas consumption	m <sup>3</sup> /h	0,8/5,1	1,1/6,9	1,5/9,2	1,5/11,8	2,1/12,8	2,1/15,1
Integrated backdraught shutter		Yes	Yes	Yes	Yes	Yes	Yes
<b>Connection Specifications</b>							
Boiler water inlet/outlet diameter	DN	25/25	25/25	25/25	25/25	25/25	25/25
Air inlet/outlet diameter (B23)	mm	80/100	80/100	110/100	110/100	110/100	110/100
Air inlet/outlet diameter (C13/C33/C43/C53/C63/C83)	mm	150/100	150/100	150/100	150/100	150/100	150/100
Gas supply diameter	DN	20	20	25	25	25	25
<b>Electrical Specifications</b>							
Power supply	V/Hz	230/50	230/50	230/50	230/50	230/50	230/50
Electrical consumption	W	52	97	116	203	212	313
<b>General Specifications</b>							
Exchanger type		Aluminum					
Energy efficiency class		A	A				
Sound power level (Lwa)	dB(A)	57	66	59	61	66	69
Boiler dimensions (Width/Length/Height)	mm	510x540x770	510x540x770	510x540x770	510x540x770	600x540x770	600x540x770
Boiler weight (Net)	kg	60	60	70	70	82	82

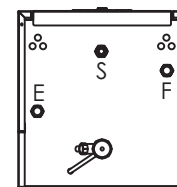
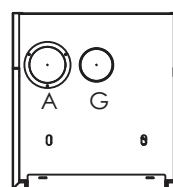
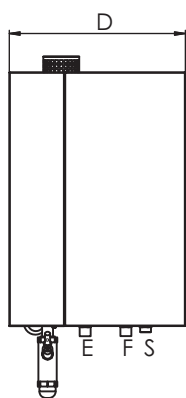
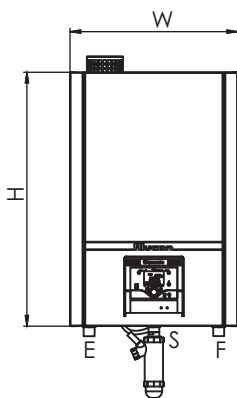

# Advantages of Condensing Boilers

- ▶ Condensation technology approximately %15 more efficient when compared with conventional systems with heat recovery
- ▶ Provides reduced fuel consumption with low flue gas temperatures and efficient combustion technology,
- ▶ Provides high modulation operation and low energy consumption with energy efficient pump,
- ▶ Provides less pollutant emissions with reduced gas consumption.

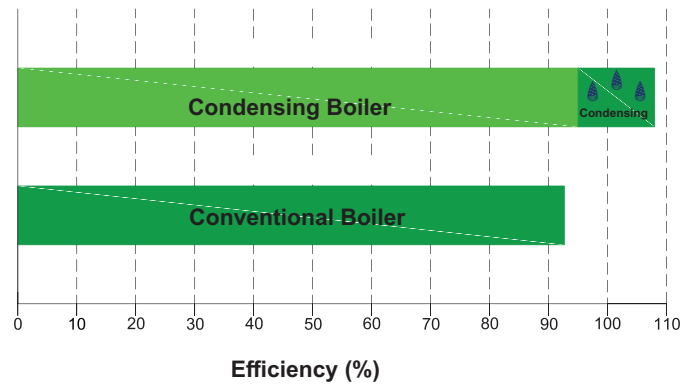

## Calculation Example:

Comparison of the natural gas consumption values between conventional and condensing boiler systems for a plant which needs 2.000.000 kcal/h and operating at 80 °C supply, 60 °C return water temperature is examined in the table below.

- Because of the conventional systems' modulation rates are lower, boiler thermal losses increase during pre-purge and post purge periods,
- Because of the conventional systems' modulation rates are lower, number of stop-starts will be more as a result of optimum time at low load decreases. It will cause increase on boiler thermal loss.
- Because of the conventional boilers are operated at higher flue temperatures, their efficiency values are lower.



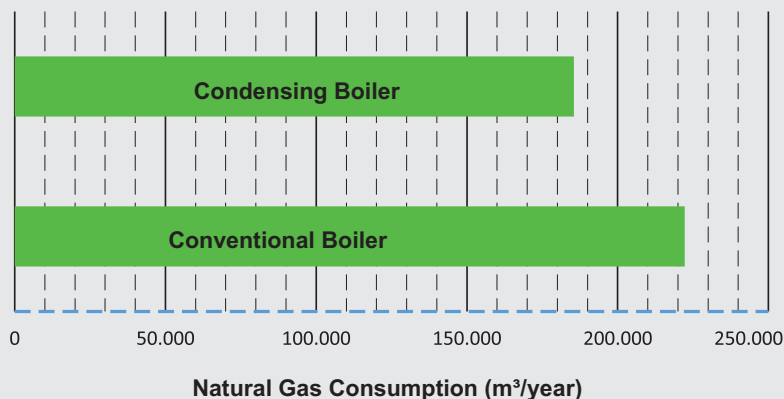

According to these reasons, conventional boilers' operation time on the same system is higher.

Calculation Example:	Unit	Conventional Boiler	Condensing Boiler
System Capacity	[kcal]	2000000	2000000
Boiler Efficiency (80-60 °C)		0.9	0.98
Natural Gas Calorific Value	[kcal/m <sup>3</sup> ]	8250.0	8250.0
Hourly Gas Consumption	[m <sup>3</sup> /h]	269.4	247.4
	[h]	5.5	5.0
Daily Working Hours	[m <sup>3</sup> ]	1481.5	1236.9
Daily Gas Consumption Difference	[m <sup>3</sup> ]	244.6	
Gas Consumption Difference (150 days)	[m <sup>3</sup> ]	36693.5	



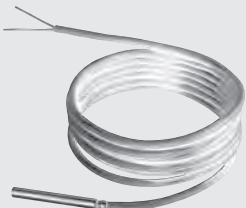

## Optional Accessories

Product Image	Product Name	Specifications
	<b>Outside Sensor</b>	Operates between -50 °C and 70 °C. Max. distance 120 m with 1.5 mm <sup>2</sup> cable. Tolerance ±1 K
	<b>Clamp Type Temperature Sensor</b>	Operates between -30 °C and 125 °C. Max. distance 120 m with 1.5 mm <sup>2</sup> cable. Tolerance ±0,5 K
	<b>Immersion Type Temperature Sensor</b>	Operates between 0 °C and 95 °C. Tolerance ±0,5 K.
	<b>External Zone Module</b>	Provides 3-way valve control function on temperature based zones. Requires additional relay and sensor connections.
	<b>Modbus Module</b>	Provides Building Management Systems (BMS) connection.

## Optional Accessories

### Websserver

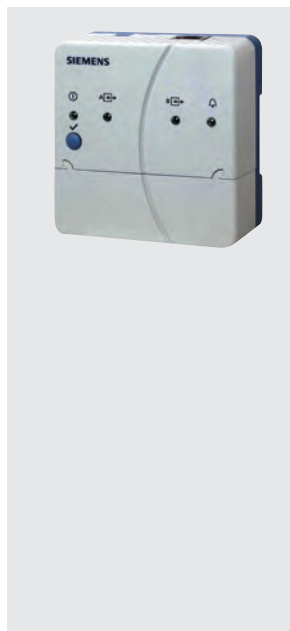

- › Controlling and displaying possibility of the boiler system from anywhere via internet,
- › Time program adjustments (heating circuit, DHW, external zone time program)
- › Temperature adjustments of the heating circuits:  
Such as DHW, swimming pool, solar energy, accumulation tank,
- › Monitoring errors and error times in the system,
- › Sending error messages up to 4 users,
- › Checking cascade parameters,
- › Setting holiday mode for heating circuits,
- › Displaying maintenance periods and define the maintenance interval,
- › Operating modes adjustment (economy, comfort, holiday and automatic operation)

## Flue Lengths

DESCRIPTION	UNIT	WALLCON					WALLCON X-TREME		
		42	50	67	70	80	115	125	150
B23	m	30	30	30	30	30	25	25	25
C13 - C33	m	15	15	15	14	-	20	18	17
C43 - C53 - C63 - C83	m	15	15	15	20	-	20	18	17

DESCRIPTION	UNIT	ALUCON					
		50	70	90	115	125	150
B23	m	25	25	25	25	22	22
C13 - C33	m	20	20	20	20	17	17
C43 - C53 - C63 - C83	m	20	20	20	20	17	17

NOTE: EFFECT OF 90° ELBOWS ON TOTAL FLUE LENGTH IS 1 METER.

# Flue Application Details

## Wallcon & Wallcon X-treme Flue Applications

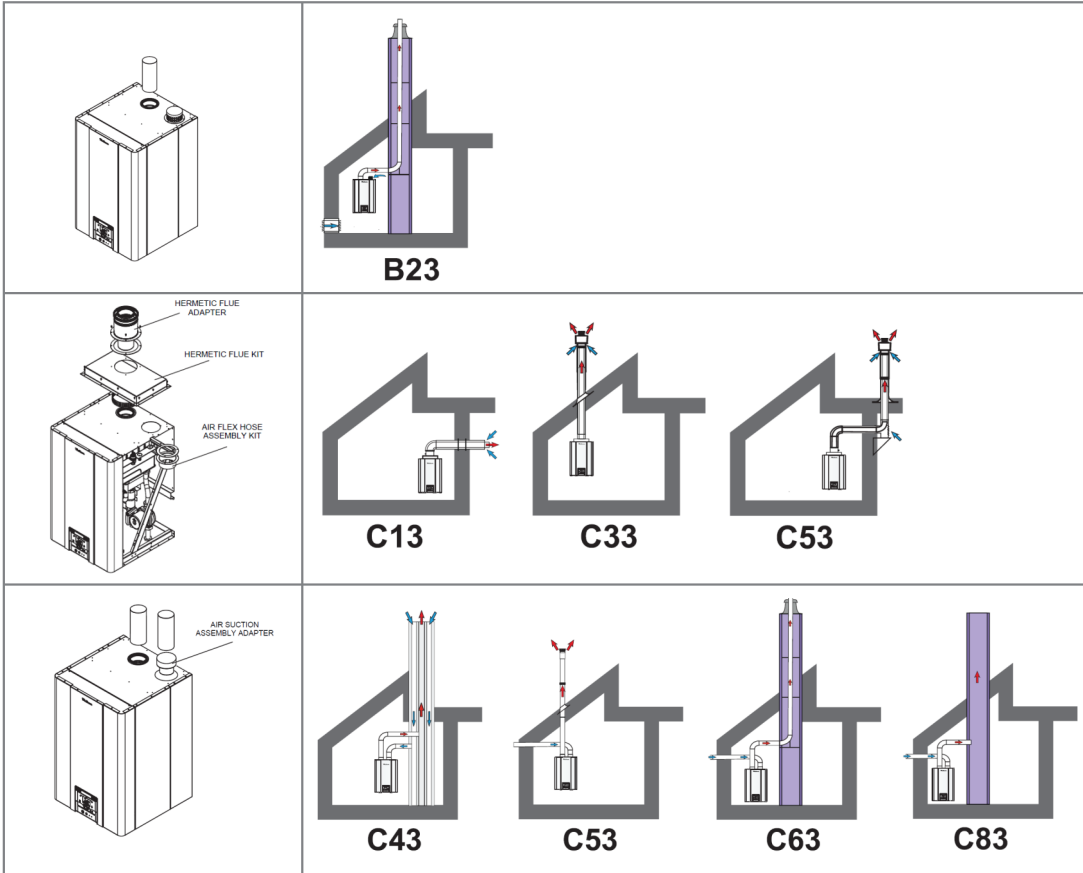

## Alucon Flue Applications

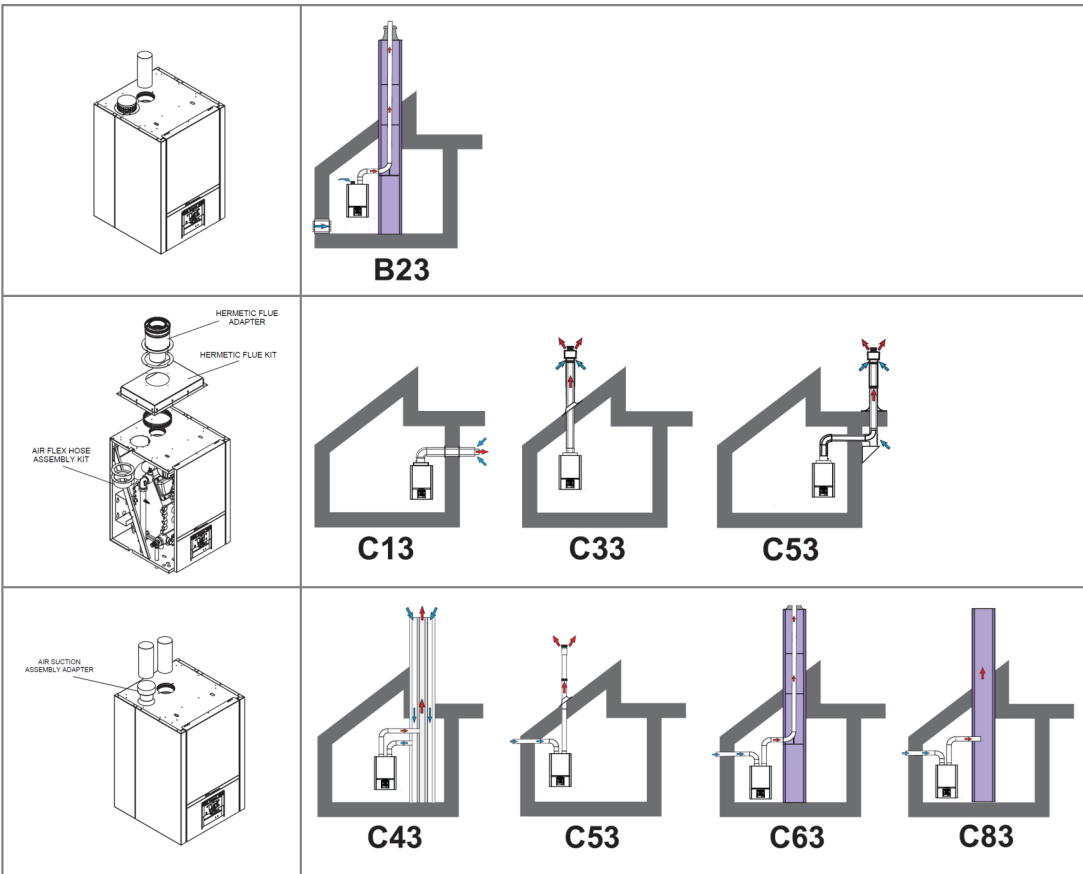

# Installation Schemas

## DHW + Floor Heating (Plate Heat Exchanger and 3 Way Valve)

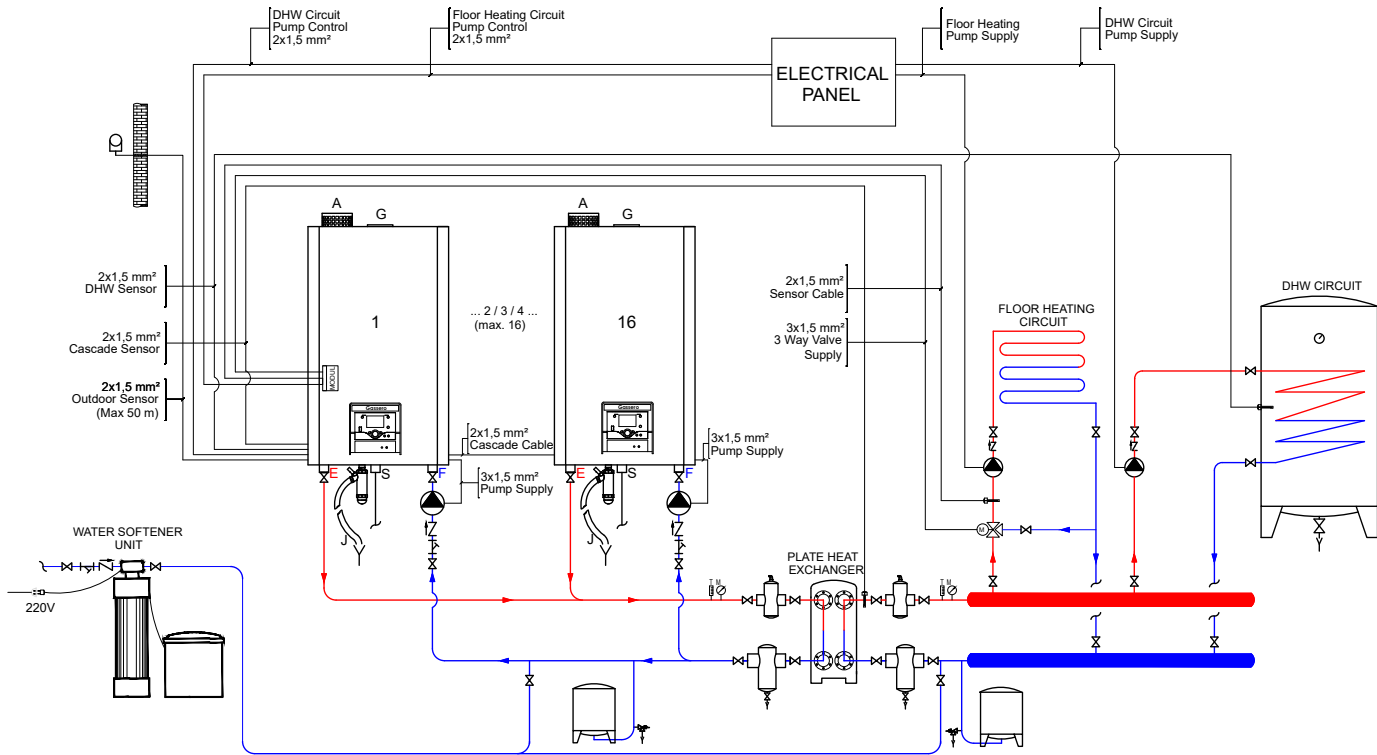

## DHW + Floor Heating (Hydraulic Separator, Plate Heat Exchanger and 3 Way Valve)

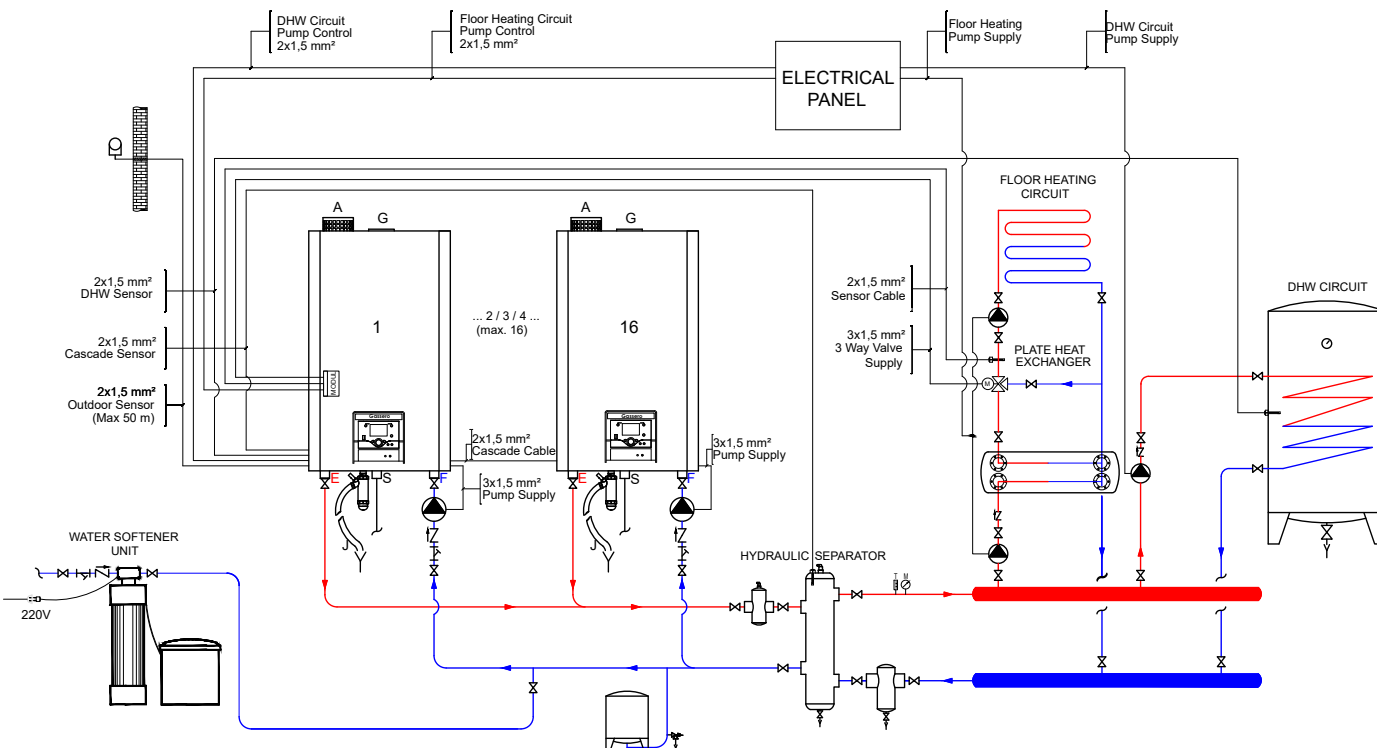

PUMP	VALVE	NON-RETURN VALVE	STRAINER	TEMPERATURE SENSOR	OUTDOOR SENSOR	AIR RELIEF VALVE	THERMOMETER	MANOMETER	SAFETY VALVE	DRAIN	AIR SEPARATOR	DIRT SEPARATOR	EXPANSION VESSEL

# Installation Schemas

## DHW + Radiator (Hydraulic Separator)

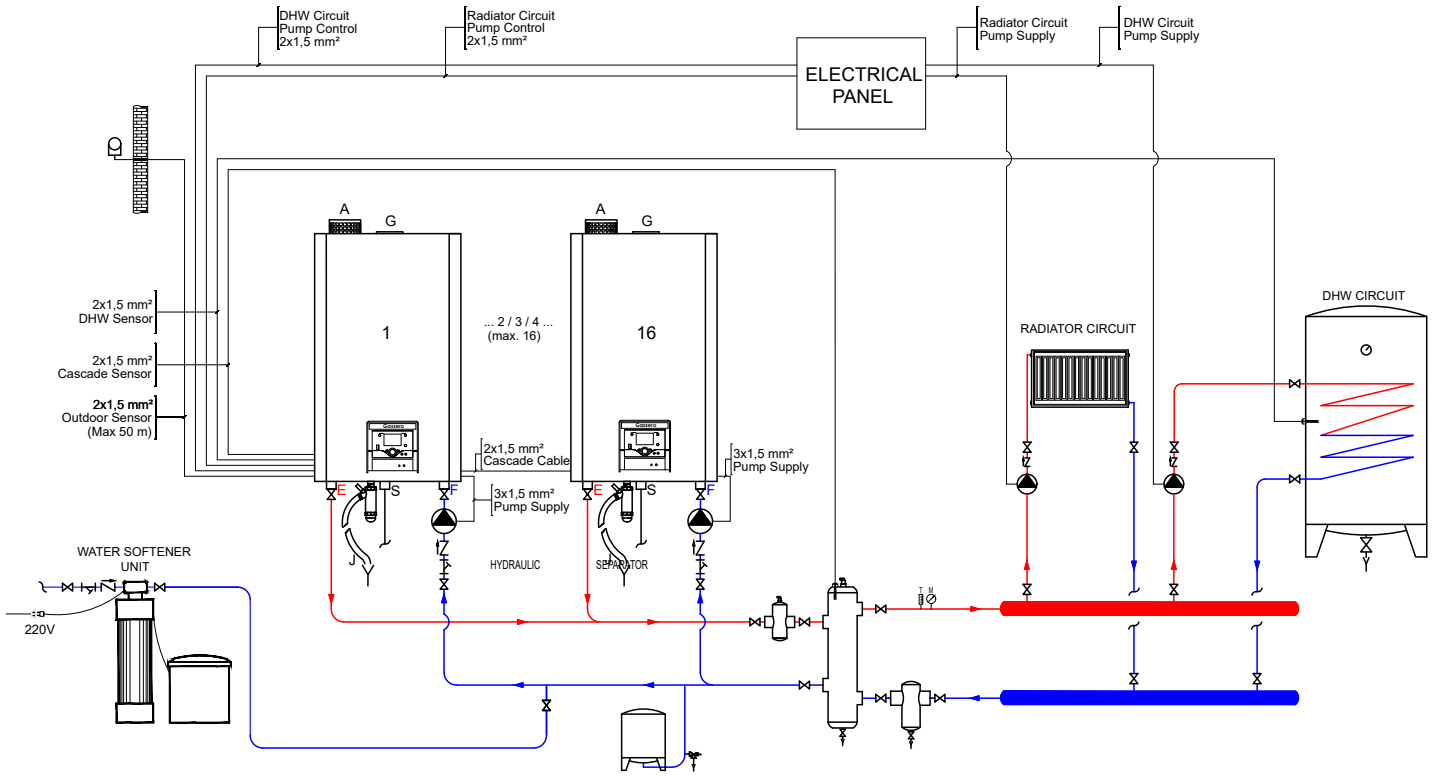

## DHW + Radiator (Hydraulic Separator and 3 Way Valve)

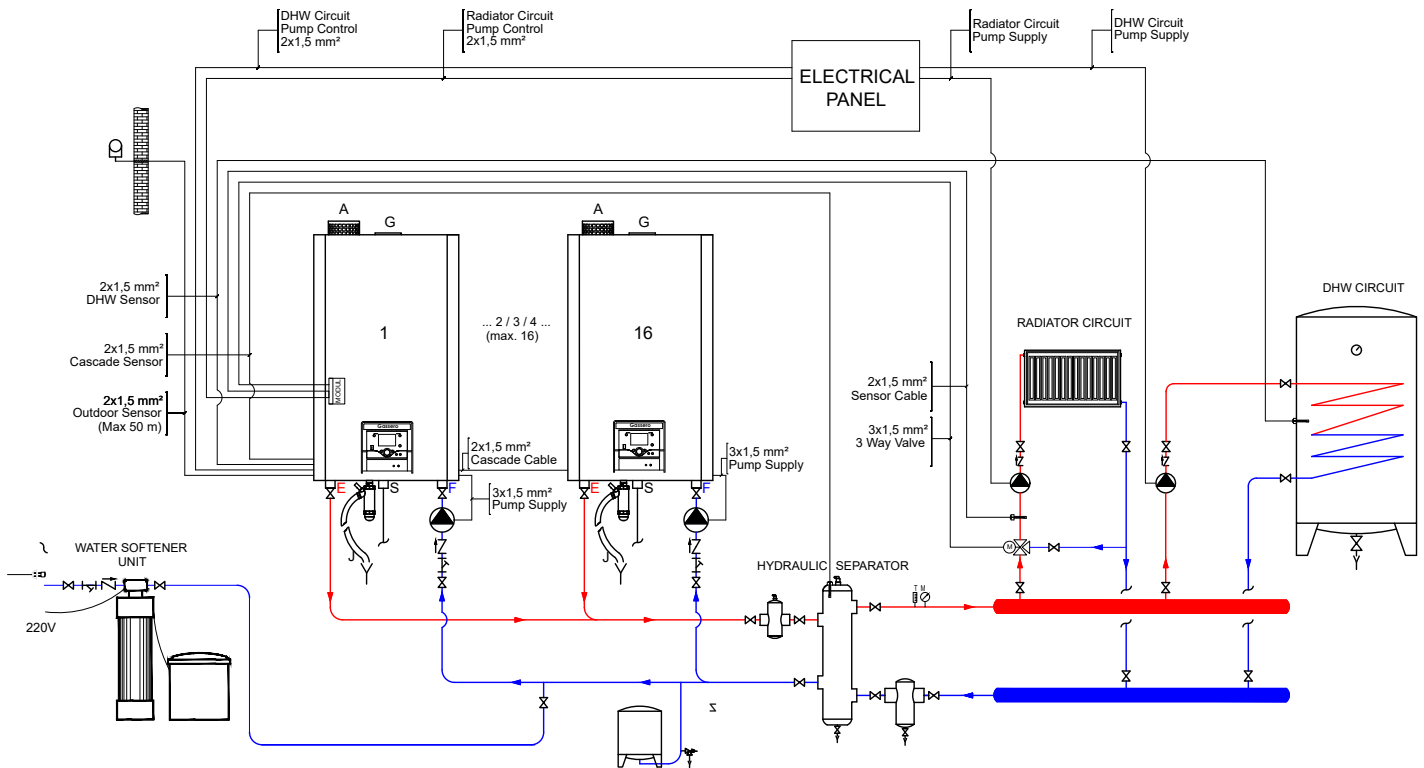

PUMP	VALVE	NON-RETURN VALVE	STRAINER	TEMPERATURE SENSOR	OUTDOOR SENSOR	AIR RELIEF VALVE	THERMOMETER	MANOMETER	SAFETY VALVE	DRAIN	AIR SEPARATOR	DIRT SEPARATOR	EXPANSION VESSEL

# Installation Schemas

## DHW + High Temperature Circuit + Radiator (Hydraulic Separator and 3 Way Valve)

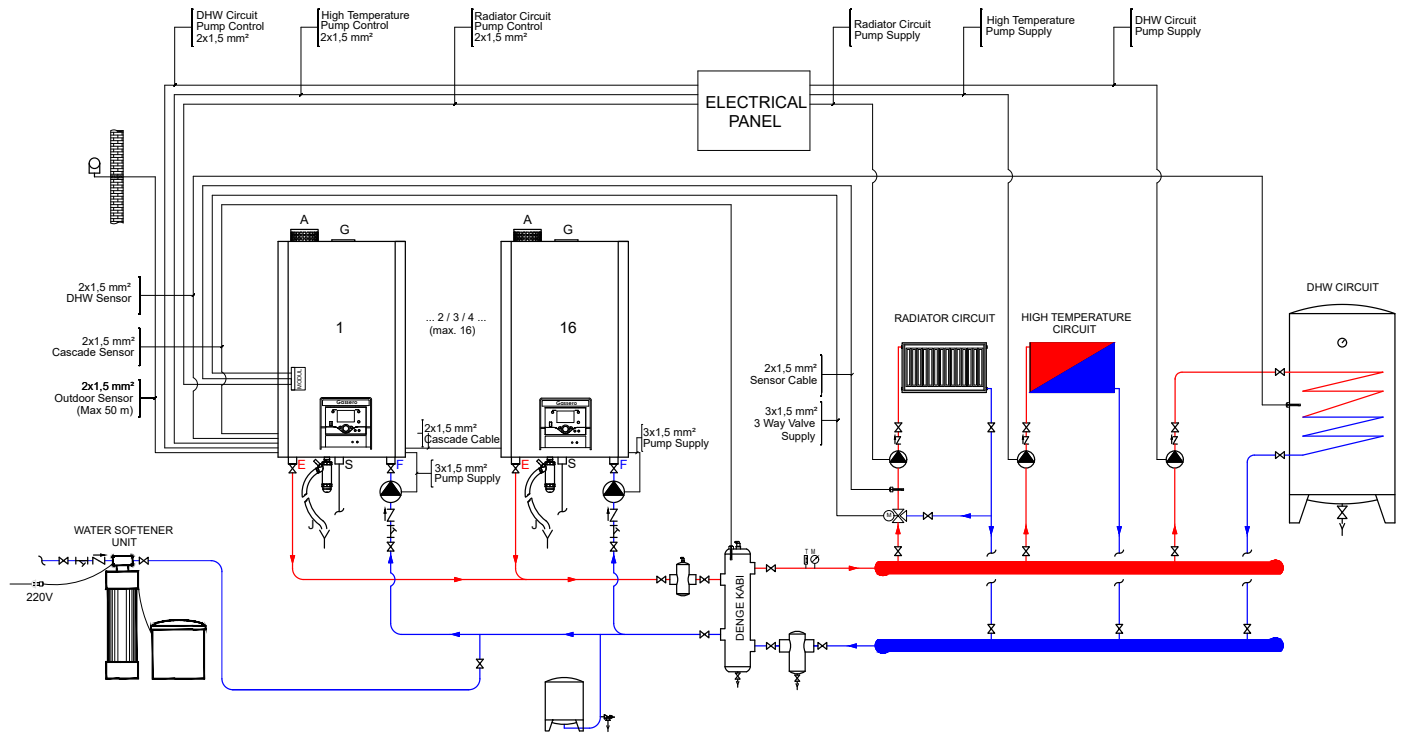

## DHW + High Temperature Circuit + Radiator (Plate Heat Exchanger and 3 Way Valve)

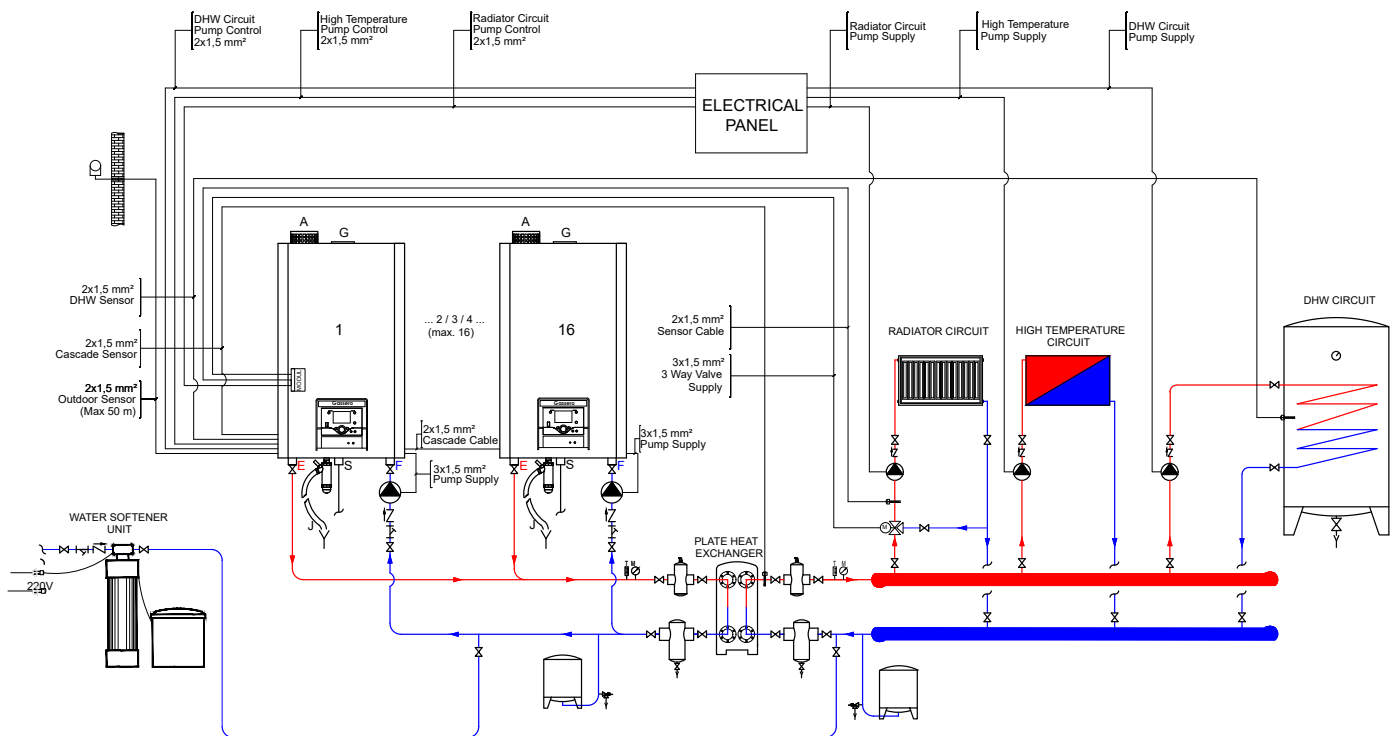

PUMP	VALVE	NON-RETURN VALVE	STRAINER	TEMPERATURE SENSOR	OUTDOOR SENSOR	AIR RELIEF VALVE	THERMOMETER	MANOMETER	SAFETY VALVE	DRAIN	AIR SEPARATOR	DIRT SEPARATOR	EXPANSION VESSEL

# BOILER ROOM APPLICATION RECOMMENDATIONS

**Gassero** is strictly advising to use water softening unit before commissioning process for long term usage. Otherwise, system could harm because of undesirable substances.

It is highly recommended to use plate heat exchanger, if there is floor heating system on the heatingline.

The devices that are commissioned outside of the required conditions, could be out of warranty.

Water Condition Range					
Total Hardness °d	pH (Aluminium)	pH (Stainless)	Iron (Not Diluted)	Conductivity	Flushing
1	6,5-8,5	7,5-9,5	<10ppm	≤2000µS/cm	It is mandatory to comply with BSRIA 7593 (See: Gassero Flushing Process)

## WATER CONDITIONS

Nitrite protection should not be used in boilers with aluminum heat exchangers

As GASSERO, we recommend flushing in the system to prolong the life of system and boilers. No acid-based products should be used during flushing.

The water used in the installation have to be city-water. **Never use well-water**

The boiler have to be serviced annually. All this maintenance should be made by authorized service, water values and the water softening unit (resin, salt etc.) values should be measured and maintained by service

Depending on the water conditions specified in the table, the problems that may occur in the boiler heat exchanger could make out of warranty.

Assembly and installation should made according to Gassero sample schemes.

## HYDRAULIC

Boiler (primary) pump have to be selected to in accordance with the required pressure and flow rate.

The boiler (primary) pump have to be in the direction of the installation return line to the boiler.

The system operating pressure should match with the working pressure of boiler. Sales Engineers could give consultancy.

All heat exchanger manufacturers; recommends to use of plate exchanger instead of the hydraulic separator for separate the primary circuit and the secondary circuit.

Domestic waste system could be used for condensate water. In system with a total power of 200 KW and above, a neutralization tank must be used.

Boiler output and input diameters have to be strictly followed, other e quipment should be selected according to the this diameters. In order to install other equipment, the diameter of the boiler out should not be reduced.

It is mandatory to use a suitable diameter filter and check valve to the boiler return line pipe at each boiler turn.

Please contact our service department about detail of collector connection in installation of floor type boiler.

Additional zone control modules and sensors have to be requested if there are equipment such as three-way valves and boilers that must be checked on the heating collector. Please contact our Sales Engineer for more information.

Have to be used air separator and dirt separator with hydraulic separator.

In case the plate heat exchanger is used instead of the hydraulic separator as the system separator, expansion tank have to be placed in the primary circuit. If an automatic filling valve is used in the system, a water meter have to be used for following how much water is added to the system.

In cascade systems, the sensor housing must be placed on the hydraulic separator or on the secondary flow line. If the system is separated by a plate heat exchanger, place the sensor housing on the secondary circuit flow line.

## ELECTRIC AND FLUE

6A fuses have to be used for the power supply of the boilers. The electrical system must be grounded.

Chimney connections have to be made in accordance with the chimney types and regulations.

The flue gas analysis measuring probe (probe hole) have to be opened by the flue company for each boiler.

Boiler chimneys should be extended by a minimum 1 meter from the boiler flue outlet direction and then connected to the chimney collector without elbows or with elbows.

If the chimney connections passes over the boiler, the connections should be checked properly and water tightening should be provided. Water in the chimney due to leaks may cause the system out of warranty. Adequate ventilation should be provided for the boiler room.

## GAS AND OTHER

The operating pressure of the boilers in the natural gas installation is 21 Mbar. Therefore, it is necessary to use a regulator in the gas line. There should be a minimum distance of 1-2 meters between the regulator and the boiler gas flange. There should be discharge line after regulator for discharge of the excess air.

In order to control the gas pressures, the manometer must be fitted before and after the regulator.

Gassero boilers are manufactured for heating and domestic water. Not suitable for commercial or industrial purposes. **GASSERO shall not be held responsible for any problems arising out of the design purpose.**

[www.gassero.com](http://www.gassero.com)

**Gassero**  
technology for your comfort

**Gassero Isı Teknolojileri San. Ltd.**  
İstanbul Endüstri ve Ticaret Serbest Bölgesi (Free Zone)  
4.Sokak No:8 34957 Tuzla / İstanbul  
T: +90 (216) 394 09 85



Rev. 05S / 20.02.2023